

CS350: Operating Systems

Lecture 12: File systems

Ali Mashtizadeh

University of Waterloo

File system fun

- File systems: traditionally hardest part of OS
 - ▶ More papers on FSES than any other single topic
- Main tasks of file system:
 - ▶ Don't go away (ever)
 - ▶ Associate bytes with name (files)
 - ▶ Associate names with each other (directories)
 - ▶ Can implement file systems on disk, over network, in memory, in non-volatile ram (NVRAM), on tape, w/ paper.
 - ▶ We'll focus on disk and generalize later
- Today: files, directories, and a bit of performance

Why disks are different

- Disk = First state we've seen that doesn't go away

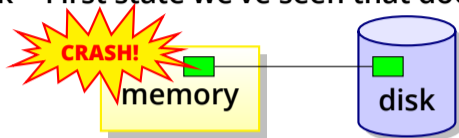

- ▶ So: Where all important state ultimately resides
- Slow (milliseconds access vs. nanoseconds for memory)

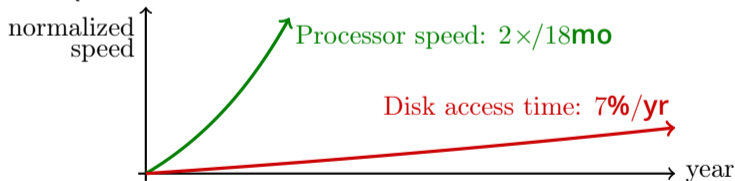

- Huge (100–1,000x bigger than memory)
 - ▶ How to organize large collection of ad hoc information?
 - ▶ Taxonomies! (Basically FS = general way to make these)

Disk vs. Memory

	Disk	MLC NAND Flash	DRAM
Smallest write	sector	sector	byte
Atomic write	sector	sector	byte/word
Random read	8 ms	75 μ s	50 ns
Random write	8 ms	300 μ s*	50 ns
Sequential read	100 MB/s	250 MB/s	> 1 GB/s
Sequential write	100 MB/s	170 MB/s*	> 1 GB/s
Cost	\$0.04/GB	\$0.65/GB	\$10/GiB
Persistence	Non-volatile	Non-volatile	Volatile

*Flash write performance degrades over time

Disk review

- Disk reads/writes in terms of sectors, not bytes
 - ▶ Read/write single sector or adjacent groups



- How to write a single byte? “Read-modify-write”

- ▶ Read in sector containing the byte



- ▶ Modify that byte

- ▶ Write entire sector back to disk



- ▶ Key: if cached, don't need to read in

- Sector = unit of atomicity.

- ▶ Sector write done completely, even if crash in middle (disk saves up enough momentum to complete)



- Larger atomic units have to be synthesized by OS

Some useful trends

- Disk bandwidth and cost/bit improving exponentially
 - ▶ Similar to CPU speed, memory size, etc.
- Seek time and rotational delay improving *very* slowly
 - ▶ Why? require moving physical object (disk arm)
- Disk accesses a huge system bottleneck & getting worse
 - ▶ Bandwidth increase lets system (pre-)fetch large chunks for about the same cost as small chunk.
 - ▶ Trade bandwidth for latency if you can get lots of related stuff.
 - ▶ How to get related stuff? Cluster together on disk
- Desktop memory size increasing faster than typical workloads
 - ▶ More and more of workload fits in file cache
 - ▶ Disk traffic changes: mostly writes and new data
 - ▶ Doesn't necessarily apply to big server-side jobs

Files: named bytes on disk

- File abstraction:

- ▶ User's view: named sequence of bytes

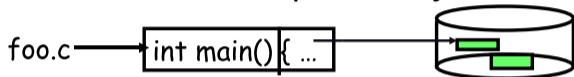

- ▶ FS's view: collection of disk blocks

- ▶ File system's job: translate name & offset to disk blocks:



- File operations:

- ▶ Create a file, delete a file
- ▶ Read from file, write to file

- Want: operations to have as few disk accesses as possible & have minimal space overhead (group related things)

What's hard about grouping blocks?

- Like page tables, file system metadata are simply data structures used to construct mappings

- ▶ Page table: map virtual page # to physical page #



- ▶ File metadata: map byte offset to disk block address



- ▶ Directory: map name to disk address or file #



FS vs. VM

- In both settings, want location transparency
- In some ways, FS has easier job than than VM:
 - ▶ CPU time to do FS mappings not a big deal (= no TLB)
 - ▶ Page tables deal with sparse address spaces and random access, files often denser ($0 \dots \text{filesize} - 1$), ~sequentially accessed
- In some ways FS's problem is harder:
 - ▶ Each layer of translation = potential disk access
 - ▶ Space a huge premium! (But disk is huge?!?!) Reason? Cache space never enough; amount of data you can get in one fetch never enough
 - ▶ Range very extreme: Many files < 10 KB, some files many GB

Some working intuitions

- FS performance dominated by # of disk accesses
 - ▶ Say each access costs ~ 10 milliseconds
 - ▶ Touch the disk 100 extra times = 1 *second*
 - ▶ Can do a *billion* ALU ops in same time!
- Access cost dominated by movement, not transfer:

seek time + rotational delay + # bytes/disk-bw

- ▶ 1 sector: $5\text{ms} + 4\text{ms} + 5\mu\text{s}$ ($\approx 512 \text{ B}/(100 \text{ MB/s})$) $\approx 9\text{ms}$
 - ▶ 50 sectors: $5\text{ms} + 4\text{ms} + .25\text{ms} = 9.25\text{ms}$
 - ▶ Can get **50x the data for only $\sim 3\%$ more overhead!**
- Observations that might be helpful:
 - ▶ All blocks in file tend to be used together, sequentially
 - ▶ All files in a directory tend to be used together
 - ▶ All names in a directory tend to be used together

Common addressing patterns

- Sequential:
 - ▶ File data processed in sequential order
 - ▶ By far the most common mode
 - ▶ Example: editor writes out new file, compiler reads in file, etc
- Random access:
 - ▶ Address any block in file directly without passing through predecessors
 - ▶ Examples: data set for demand paging, databases
- Keyed access
 - ▶ Search for block with particular values
 - ▶ Examples: associative data base, index
 - ▶ Usually not provided by OS

Problem: how to track file's data

- Disk management:
 - ▶ Need to keep track of where file contents are on disk
 - ▶ Must be able to use this to map byte offset to disk block
 - ▶ Structure tracking a file's sectors is called an index node or *inode*
 - ▶ Inodes must be stored on disk, too
- Things to keep in mind while designing file structure:
 - ▶ Most files are small
 - ▶ Much of the disk is allocated to large files
 - ▶ Many of the I/O operations are made to large files
 - ▶ Want good sequential and good random access
(what do these require?)

Straw man: contiguous allocation

- “Extent-based”: allocate files like segmented memory
 - ▶ When creating a file, make the user pre-specify its length and allocate all space at once
 - ▶ Inode contents: location and size

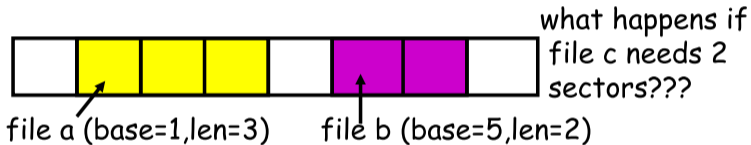

- Example: IBM OS/360
- Pros?
- Cons? (Think of corresponding VM scheme)

Straw man: contiguous allocation

- “Extent-based”: allocate files like segmented memory
 - ▶ When creating a file, make the user pre-specify its length and allocate all space at once
 - ▶ Inode contents: location and size

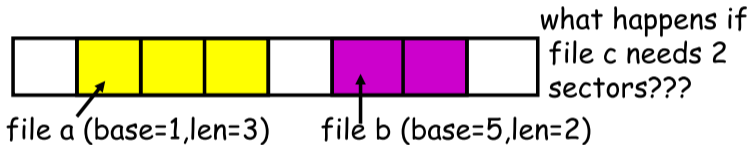

- Example: IBM OS/360
- Pros?
 - ▶ Simple, fast access, both sequential and random
- Cons? (Think of corresponding VM scheme)
 - ▶ External fragmentation

Linked files

- Basically a linked list on disk.
 - ▶ Keep a linked list of all free blocks
 - ▶ Inode contents: a pointer to file's first block
 - ▶ In each block, keep a pointer to the next one

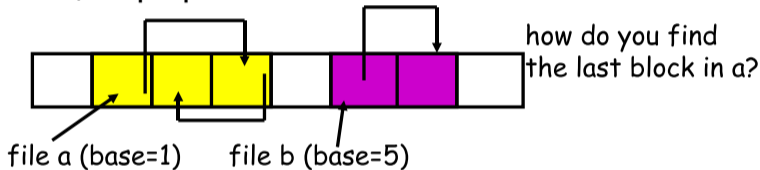

- Examples (sort-of): Alto, TOPS-10, DOS FAT
- Pros?
- Cons?

Linked files

- Basically a linked list on disk.
 - ▶ Keep a linked list of all free blocks
 - ▶ Inode contents: a pointer to file's first block
 - ▶ In each block, keep a pointer to the next one

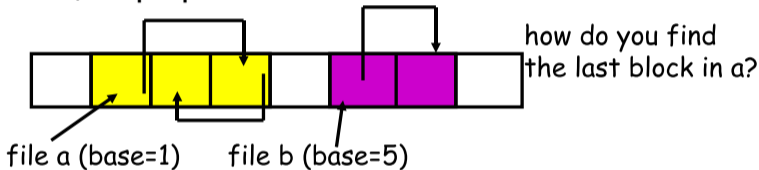

- Examples (sort-of): Alto, TOPS-10, DOS FAT
- Pros?
 - ▶ Easy dynamic growth & sequential access, no fragmentation
- Cons?
 - ▶ Linked lists on disk a bad idea because of access times
 - ▶ Pointers take up room in block, skewing alignment

Example: DOS FS (simplified)

- Uses linked files. Cute: links reside in fixed-sized “file allocation table” (FAT) rather than in the blocks.

Directory (5) FAT (16-bit entries)

a: 6
b: 2

0	free
1	eof
2	1
3	eof
4	3
5	eof
6	4
	...

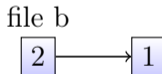

- Still do pointer chasing, but can cache entire FAT so can be cheap compared to disk access

FAT discussion

- Entry size = 16 bits
 - ▶ What's the maximum size of the FAT?
 - ▶ Given a 512 byte block, what's the maximum size of FS?
 - ▶ One solution: go to bigger blocks. Pros? Cons?
- Space overhead of FAT is trivial:
 - ▶ 2 bytes / 512 byte block = $\sim 0.4\%$ (Compare to Unix)
- Reliability: how to protect against errors?
 - ▶ Create duplicate copies of FAT on disk
 - ▶ State duplication a very common theme in reliability
- Bootstrapping: where is root directory?

- ▶ Fixed location on disk:



FAT discussion

- Entry size = 16 bits
 - ▶ What's the maximum size of the FAT? **65,536 entries**
 - ▶ Given a 512 byte block, what's the maximum size of FS? **32 MiB**
 - ▶ One solution: go to bigger blocks. Pros? Cons?
- Space overhead of FAT is trivial:
 - ▶ 2 bytes / 512 byte block = $\sim 0.4\%$ (Compare to Unix)
- Reliability: how to protect against errors?
 - ▶ Create duplicate copies of FAT on disk
 - ▶ State duplication a very common theme in reliability
- Bootstrapping: where is root directory?

- ▶ Fixed location on disk:



Indexed files

- Each file has an array holding all of it's block pointers
 - ▶ Just like a page table, so will have similar issues
 - ▶ Max file size fixed by array's size (static or dynamic?)
 - ▶ Allocate array to hold file's block pointers on file creation
 - ▶ Allocate actual blocks on demand using free list

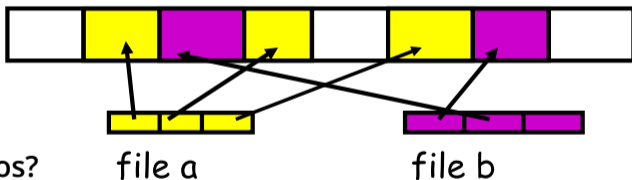

- Pros?
- Cons?

Indexed files

- Each file has an array holding all of its block pointers
 - ▶ Just like a page table, so will have similar issues
 - ▶ Max file size fixed by array's size (static or dynamic?)
 - ▶ Allocate array to hold file's block pointers on file creation
 - ▶ Allocate actual blocks on demand using free list

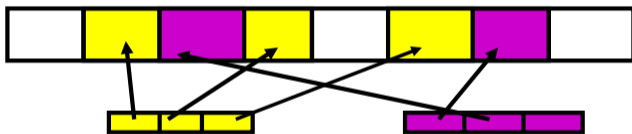

- Pros?
 - ▶ Both sequential and random access easy
- Cons?
 - ▶ Mapping table requires large chunk of contiguous space
...Same problem we were trying to solve initially

Indexed files

- Issues same as in page tables

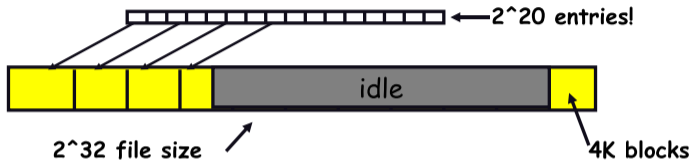

- ▶ Large possible file size = lots of unused entries
- ▶ Large actual size? table needs large contiguous disk chunk
- Solve identically: small regions with index array, this array with another array, ... Downside?



Multi-level indexed files (old BSD FS)

- Solve problem of first block access slow
- inode = 14 block pointers + "stuff"

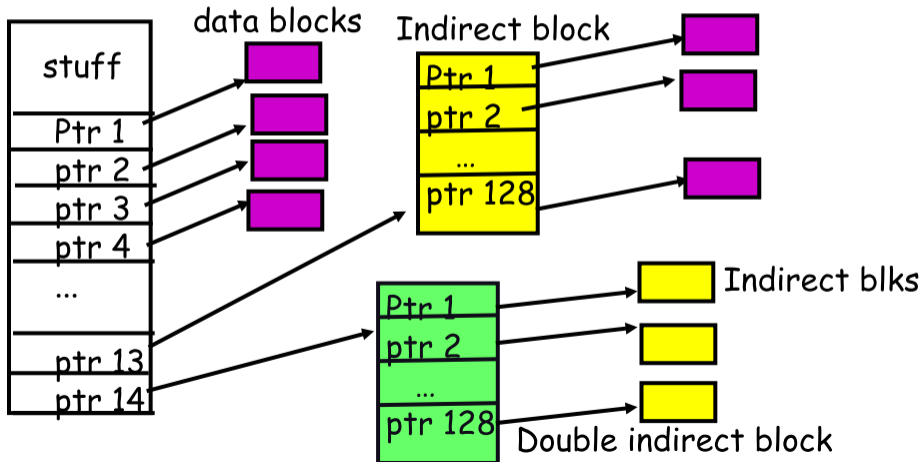

Old BSD FS discussion

- Pros:
 - ▶ Simple, easy to build, fast access to small files
 - ▶ Maximum file length fixed, but large.
- Cons:
 - ▶ What is the worst case # of accesses?
 - ▶ What is the worst-case space overhead? (e.g., 13 block file)
- An empirical problem:
 - ▶ Because you allocate blocks by taking them off unordered freelist, metadata and data get strewn across disk

More about inodes

- Inodes are stored in a fixed-size array
 - ▶ Size of array fixed when disk is initialized; can't be changed
 - ▶ Lives in known location, originally at one side of disk:



- ▶ Now is smeared across it (why?)

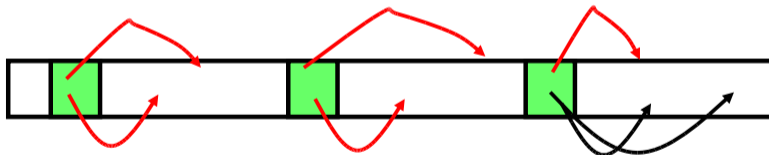

- ▶ The index of an inode in the inode array called an i-number
- ▶ Internally, the OS refers to files by inumber
- ▶ When file is opened, inode brought in memory
- ▶ Written back when modified and file closed or time elapses

Directories

- **Problem:**
 - ▶ “Spend all day generating data, come back the next morning, want to use it.” – F. Corbato, on why files/dirs invented
- **Approach 0: Have users remember where on disk their files are**
 - ▶ (E.g., like remembering your social security or bank account #)
- **Yuck. People want human digestible names**
 - ▶ We use directories to map names to file blocks
- **Next: What is in a directory and why?**

A short history of directories

- Approach 1: Single directory for entire system
 - ▶ Put directory at known location on disk
 - ▶ Directory contains $\langle \text{name}, \text{inumber} \rangle$ pairs
 - ▶ If one user uses a name, no one else can
 - ▶ Many ancient personal computers work this way
- Approach 2: Single directory for each user
 - ▶ Still clumsy, and 1s on 10,000 files is a real pain
- Approach 3: Hierarchical name spaces
 - ▶ Allow directory to map names to files *or other dirs*
 - ▶ File system forms a tree (or graph, if links allowed)
 - ▶ Large name spaces tend to be hierarchical (ip addresses, domain names, scoping in programming languages, etc.)

Hierarchical Unix



- Used since CTSS (1960s)
 - ▶ Unix picked up and used really nicely
- Directories stored on disk just like regular files
 - ▶ Special inode type byte set to directory
 - ▶ User's can read just like any other file
 - ▶ Only special syscalls can write (why?)
 - ▶ Inodes at fixed disk location
 - ▶ File pointed to by the index may be another directory
 - ▶ Makes FS into hierarchical tree (what needed to make a DAG?)
- Simple, plus speeding up file ops speeds up dir ops!

```
<name,inode#>
<afs,1021>
<tmp,1020>
<bin,1022>
<cdrom,4123>
<dev,1001>
<sbin,1011>
⋮
```

Naming magic

- Bootstrapping: Where do you start looking?
 - ▶ Root directory always inode #2 (0 and 1 historically reserved)
- Special names:
 - ▶ Root directory: `"/"`
 - ▶ Current directory: `"."`
 - ▶ Parent directory: `".."`
- Special names not implemented in FS:
 - ▶ User's home directory: `"~"`
 - ▶ Globbing: `"foo.*"` expands to all files starting `"foo."`
- Using the given names, only need two operations to navigate the entire name space:
 - ▶ `cd name`: move into (change context to) directory *name*
 - ▶ `ls`: enumerate all names in current directory (context)

Unix example: /a/b/c.c

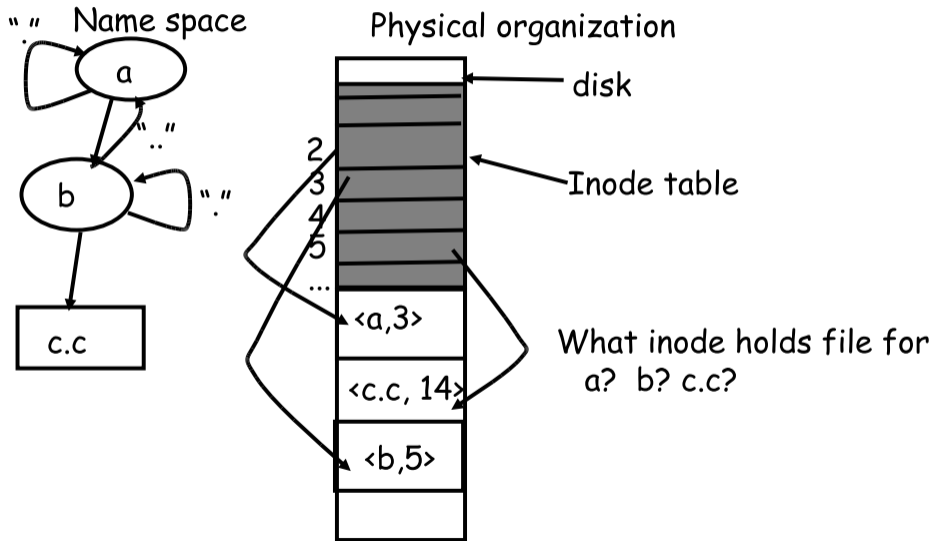

Default context: working directory

- Cumbersome to constantly specify full path names
 - ▶ In Unix, each process associated with a “current working directory” (cwd)
 - ▶ File names not beginning with “/” are assumed to be relative to cwd; otherwise translation happens as before
 - ▶ Editorial: root, cwd should be regular fds (like stdin, stdout, ...) with *openat* syscall instead of *open*
- Shells track a default list of active contexts
 - ▶ A “search path” for programs you run
 - ▶ Given a search path A : B : C, a shell will check in A, then check in B, then check in C
 - ▶ Can escape using explicit paths: “./foo”
- Example of locality

Hard and soft links (synonyms)

- More than one dir entry can refer to a given file

- ▶ Unix stores count of pointers (“hard links”) to inode
- ▶ To make: “ln foo bar” creates a synonym (bar) for *file* foo

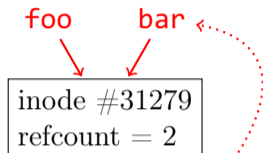

- Soft/symbolic links = synonyms for *names*

- ▶ Point to a file (or dir) *name*, but object can be deleted from underneath it (or never even exist).
- ▶ Unix implements like directories: inode has special “symlink” bit set and contains name of link target

ln -s /bar baz

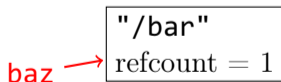

- ▶ When the file system encounters a symbolic link it automatically translates it (if possible).

Case study: speeding up FS

- Original Unix FS: Simple and elegant:

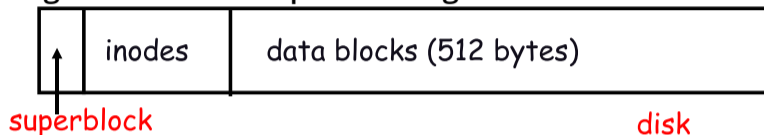

- Components:
 - ▶ Data blocks
 - ▶ Inodes (directories represented as files)
 - ▶ Hard links
 - ▶ Superblock. (specifies number of blks in FS, counts of max # of files, pointer to head of free list)
- Problem: slow
 - ▶ Only gets 20Kb/sec (2% of disk maximum) even for sequential disk transfers!

A plethora of performance costs

- Blocks too small (512 bytes)
 - ▶ File index too large
 - ▶ Too many layers of mapping indirection
 - ▶ Transfer rate low (get one block at time)
- Poor clustering of related objects:
 - ▶ Consecutive file blocks not close together
 - ▶ Inodes far from data blocks
 - ▶ Inodes for directory not close together
 - ▶ Poor enumeration performance: e.g., `"ls"`, `"grep foo *.c"`
- Usability problems
 - ▶ 14-character file names a pain
 - ▶ Can't atomically update file in crash-proof way
- Next: how FFS fixes these (to a degree) [\[McKusic\]](#)

Problem: Internal fragmentation

- Block size was too small in Unix FS
- Why not just make block size bigger?

Block size	space wasted	file bandwidth
512	6.9%	2.6%
1024	11.8%	3.3%
2048	22.4%	6.4%
4096	45.6%	12.0%
1MB	99.0%	97.2%

- Bigger block increases bandwidth, but how to deal with wastage (“internal fragmentation”)?
 - ▶ Use idea from malloc: split unused portion.

Solution: fragments

- BSD FFS:
 - ▶ Has large block size (4096 or 8192)
 - ▶ Allow large blocks to be chopped into small ones (“fragments”)
 - ▶ Used for little files and pieces at the ends of files

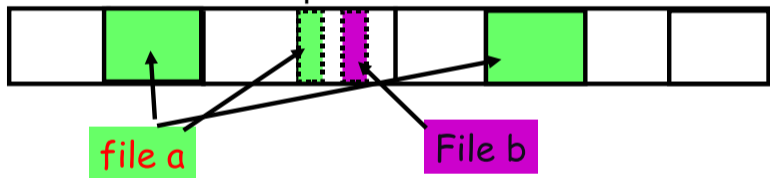

- Best way to eliminate internal fragmentation?
 - ▶ Variable sized splits of course
 - ▶ Why does FFS use fixed-sized fragments (1024, 2048)?

Clustering related objects in FFS

- Group 1 or more consecutive cylinders into a "*cylinder group*"

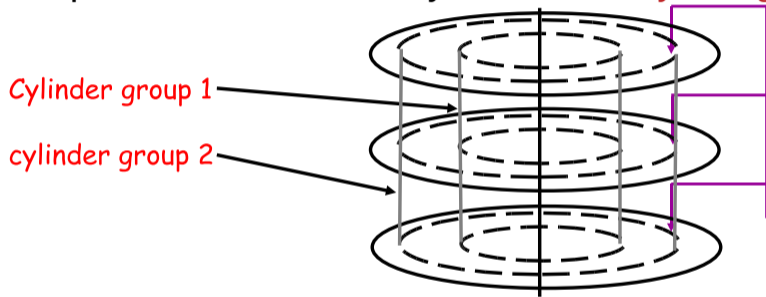

- ▶ Key: can access any block in a cylinder without performing a seek. Next fastest place is adjacent cylinder.
- ▶ Tries to put everything related in same cylinder group
- ▶ Tries to put everything not related in different group (?!)

Clustering in FFS

- Tries to put sequential blocks in adjacent sectors
 - ▶ (Access one block, probably access next)

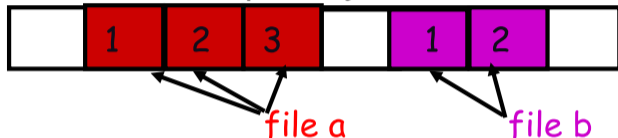

- Tries to keep inode in same cylinder as file data:
 - ▶ (If you look at inode, most likely will look at data too)

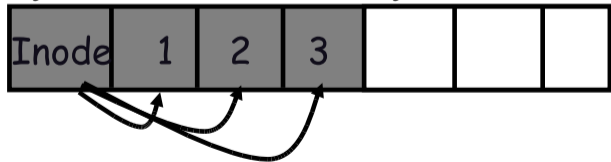

- Tries to keep all inodes in a dir in same cylinder group
 - ▶ Access one name, frequently access many, e.g., "ls -l"

What does disk layout look like?

- Each cylinder group basically a mini-Unix file system:

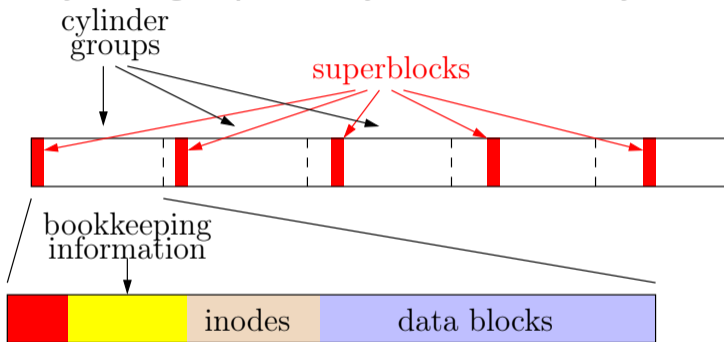

- How to ensure there's space for related stuff?
 - ▶ Place different directories in different cylinder groups
 - ▶ Keep a "free space reserve" so can allocate near existing things
 - ▶ When file grows too big (1MB) send its remainder to different cylinder group.

Finding space for related objs

- Old Unix (& DOS): Linked list of free blocks

- ▶ Just take a block off of the head. Easy.

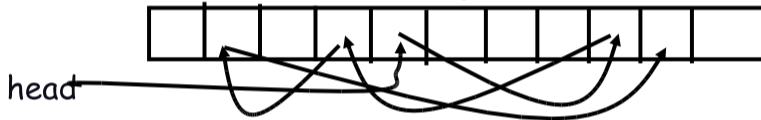

- ▶ Bad: free list gets jumbled over time. Finding adjacent blocks hard and slow

- FFS: switch to bit-map of free blocks

- ▶ 10101011111100000111111000101100
- ▶ Easier to find contiguous blocks.
- ▶ Small, so usually keep entire thing in memory
- ▶ Time to find free block increases if fewer free blocks

Using a bitmap

- Usually keep entire bitmap in memory:
 - ▶ 4G disk / 4K byte blocks. How big is map?
- Allocate block close to block x ?
 - ▶ Check for blocks near `bmap[x/32]`
 - ▶ If disk almost empty, will likely find one near
 - ▶ As disk becomes full, search becomes more expensive and less effective
- Trade space for time (search time, file access time)
- Keep a reserve (e.g, 10%) of disk always free, ideally scattered across disk
 - ▶ Don't tell users (`df` can get to 110% full)
 - ▶ Only root can allocate blocks once FS 100% full
 - ▶ With 10% free, can almost always find one of them free

So what did we gain?

- Performance improvements:
 - ▶ Able to get 20-40% of disk bandwidth for large files
 - ▶ 10-20x original Unix file system!
 - ▶ Better small file performance (why?)
- Is this the best we can do? No.
- Block based rather than extent based
 - ▶ Could have named contiguous blocks with single pointer and length (Linux ext2fs, XFS)
- Writes of metadata done synchronously
 - ▶ Really hurts small file performance
 - ▶ Make asynchronous with write-ordering (“soft updates”) or logging/journaling... more next lecture
 - ▶ Play with semantics (/tmp file systems)

- Obvious:
 - ▶ Big file cache
- Fact: no rotation delay if get whole track.
 - ▶ How to use?
- Fact: transfer cost negligible.
 - ▶ Recall: Can get 50x the data for only $\sim 3\%$ more overhead
 - ▶ 1 sector: $5\text{ms} + 4\text{ms} + 5\mu\text{s}$ ($\approx 512\text{ B}/(100\text{ MB/s})$) $\approx 9\text{ms}$
 - ▶ 50 sectors: $5\text{ms} + 4\text{ms} + .25\text{ms} = 9.25\text{ms}$
 - ▶ How to use?
- Fact: if transfer huge, seek + rotation negligible
 - ▶ LFS: Hoard data, write out MB at a time